

SCI® Press – Copper Fittings

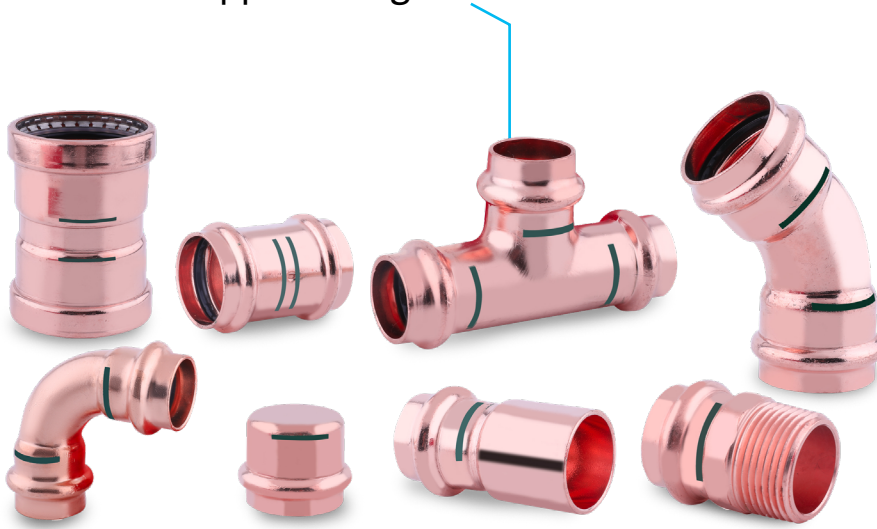

Material Specifications

Body

Copper Alloy conforming to UNS C12200

Fastening Grip Ring (2½" To 4" Only)

Stainless Steel conforming to Grade 304, UNS S304000

Spacer (2½" To 4" Only)

Nylon

O-Ring

Silicone Grease

Properties as designated in accordance with ASTM D 2000

Grade "E" EPDM

Peroxide Cured -20°F to 248°F (Operating Temperature Range) Recommended for water service, diluted acids, alkalies solutions, oil-free air and many other chemical services. NOT FOR USE IN PETROLEUM APPLICATIONS.

Approvals & Certifications

IAPMO: UPC PS-117, NSF/ANSI 61, NSF/ANSI 372

The SCI Press Technology for Copper Systems includes couplings, elbows, tees, adapters, reducers, caps, unions, and flanges for mechanical copper systems.

They provide an economical and reliable piping connection that can be used for commercial, industrial, and residential markets; eliminating the need of using conventional methods of soldering and brazing.

SCI Press Copper fitting sealing elements feature leak-if-not-pressed technology to help identify unpressed joints during the testing phase, rather than costly leaks after the system is in operation. All fittings are covered by a 50-year limited warranty.

SCI Press Copper Fittings are intended for use with ASTM B88, Types K, L, and M hard copper tubing in sizes ½" to 4" and soft copper tubing in sizes ½" to 1¼".

After visual confirmation of each connection, a system pressure test may be performed in accordance with local code requirements.

The SCI Press Technology for Copper Systems is compatible with common pressing tools and jaws.



PROJECT INFORMATION	APPROVAL STAMP
Project:	Approved
Address:	Approved as noted
Contractor:	Not approved
Engineer:	Remarks:
Submittal Date:	
Notes 1:	
Notes 2:	

Applications

SCI Press Copper Fittings are intended for use with ASTM B88 seamless copper water tube (Types K, L, & M) in residential and commercial plumbing and mechanical systems. Common applications are listed below:

Types of Service	Pressure	Temperature	EPDM Compatibility*
Liquids/Potable Water			
Water Systems	300 psi (Test pressure of 600 psi)	-20°F to 248°	Y
Steam (Residential)	5 psi	Max 227°	Y
Acetone (Liquid)	70 psi	-14° to 104°	Y
Fuel, Oil, Lubricants			
Ethanol (Pure grain alcohol)	200 psi	Ambient, less than 250°	Y
Gases			
Compressed Air (Oil concentration ≤25 mg/m3)	200 psi	Max 140°	Y
Nitrogen	200 psi	Max 140°	Y
Carbon Dioxide	200 psi	Max 140°	Y
Carbon Monoxide	200 psi	Max 140°	Y
Argon	200 psi	Max 140°	Y
Oxygen (Non-Medical, Keep free of oil and grease)	140 psi	Max 140°	Y
Hydrogen	125 psi	Max 140°	Y
Vacuum (Maximum absolute pressure)	750µm Hg	Max 160°	Y
Vacuum (Maximum differential pressure)	29.2" Hg	Max 160°	Y

*Fluids containing hydrocarbon-based oils are not compatible with the EPDM seal.

All copper tubing must comply with the ASTM B88 standard. Fittings are approved for installations above and below ground as permitted by local building codes.

Copper Fitting Alloy C1220 has been evaluated by IAPMO R&T Lab to NSF/ANSI 61 for use in drinking water supplies of pH 6.5 and above. Drinking water supplies that are less than pH 6.5 may require corrosion control to limit leaching of copper into the drinking water.



asc-es.com

Building connections that last™

SCI® Press – Copper 90° Elbow Fig. SP690

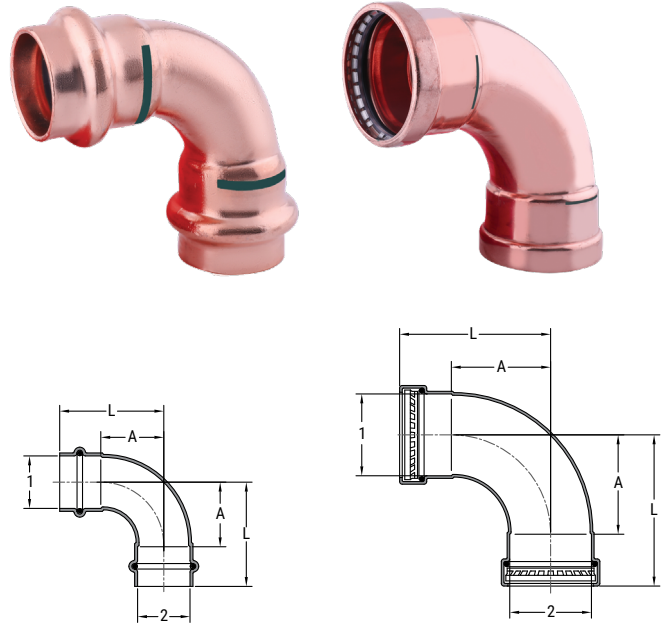

SP690 CU P X P 90 ELL

Inlet 1	Inlet 2	A	L	Weight
in.	in.	in./mm	in./mm	in./mm
½	½	0.807 20.500	1.555 39.500	0.11 0.05
¾	¾	1.142 29.000	2.028 51.500	0.19 0.08
1	1	1.358 34.500	2.244 57.000	0.28 0.13
1¼	1¼	1.555 39.500	2.638 67.000	0.43 0.19
1½	1½	1.831 46.500	3.228 82.000	0.80 0.36
2	2	2.224 56.500	3.780 96.000	1.15 0.52
2½	2½	3.209 81.500	4.882 124.000	2.10 0.95
3	3	3.780 96.000	5.720 145.500	3.03 1.38
4	4	4.902 124.500	7.244 184.000	5.73 2.60

SCI® Press – Copper 90° Street Elbow Fig. SP699



SP699 CU P X MS STREET 90 ELL

Inlet 1	Inlet 2	A	L	L1	Weight
in	in	in./mm	in./mm	in./mm	lbs/kg
½	½	0.807 20.500	1.555 39.500	1.732 44.000	0.10 0.05
¾	¾	1.142 29.000	2.028 51.500	2.126 54.000	0.18 0.08
1	1	1.358 34.500	2.244 57.000	2.362 60.000	0.27 0.12
1¼	1¼	1.555 39.500	2.638 67.000	2.933 74.500	0.40 0.18
1½	1½	1.831 46.500	3.228 82.000	3.543 90.000	0.77 0.35
2	2	2.224 56.500	3.780 96.000	4.291 109.000	1.11 0.50
2½	2½	3.209 81.500	4.882 124.000	5.354 136.000	1.96 0.89
3	3	3.780 96.000	5.728 145.500	6.260 159.000	2.86 1.30
4	4	4.921 125.000	7.264 184.500	7.835 199.000	5.51 2.50



asc-es.com

Building connections that last™

SCI Press – Copper 90° Reducing Elbow
Fig. SP690R

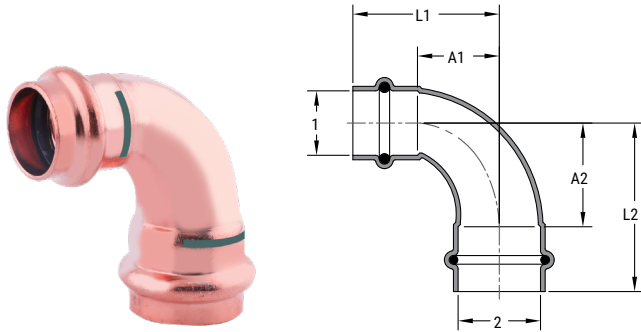

SP690R CU P X P RED 90 ELL

Inlet 1	Inlet 2	A1	A2	L1	L2	Weight
in	in	in/mm	in/mm	in/mm	in/mm	lbs/kg
½	¾	1.004 25.500	0.945 24.000	1.752 44.500	1.831 46.500	0.15 0.07
¾	1	1.122 28.500	1.417 36.000	2.008 51.000	2.303 58.500	0.25 0.11

SCI Press – Copper 90° FPT Female Elbow
Fig. SP698

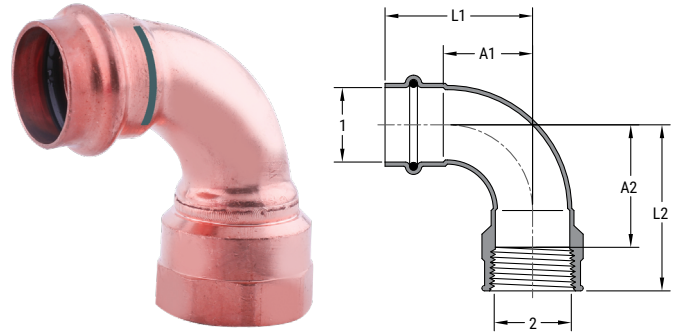

SP698 CU P X FT 90 ELL

Inlet 1	Inlet 2	A	L1	L2	Weight
in	in	in/mm	in/mm	in/mm	lbs/kg
½	¾	0.807 20.500	1.555 39.500	1.457 37.000	0.14 0.06
½	½	0.807 20.500	1.555 39.500	1.811 46.000	0.18 0.08
½	¾	0.807 20.500	1.555 39.500	1.929 49.000	0.27 0.12
¾	½	1.142 29.000	2.028 51.500	1.969 50.000	0.25 0.11
¾	¾	1.142 29.000	2.028 51.500	1.969 50.000	0.30 0.14
1	½	1.358 34.500	2.244 57.000	2.224 56.500	0.30 0.13
1	1	1.358 34.500	2.244 57.000	2.520 64.000	0.46 0.21
1¼	1¼	1.555 39.500	2.638 67.000	3.012 76.500	0.67 0.30
1½	1½	1.831 46.500	3.228 82.000	3.268 83.000	0.96 0.44
2	2	2.421 61.500	3.976 101.000	4.213 107.000	1.61 0.73

SCI Press – Copper 90°
Extended Street Elbow
Fig. SP699L

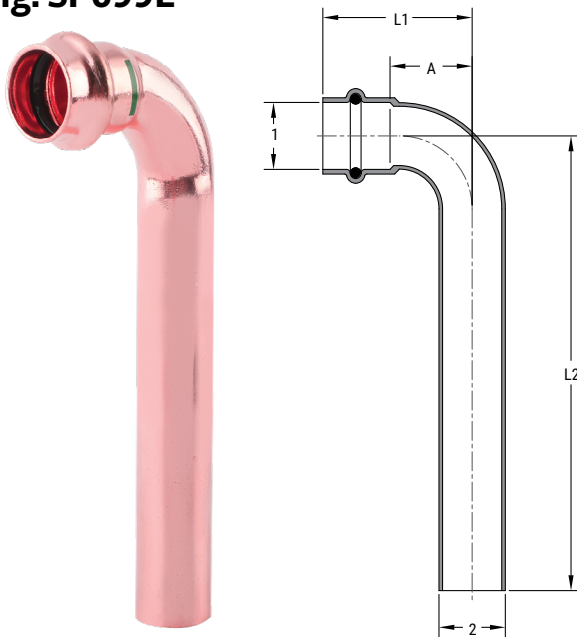

SP699L CU P X MS EXTND STREET 90 ELL

Inlet 1	Inlet 2	A	L	L1	Weight
in	in	in/mm	in/mm	in/mm	lbs/kg
¾	¾	1.083 27.500	1.969 50.000	5.984 152.000	0.39 0.18



asc-es.com

Building connections that last™

SCI Press – Copper 45° Elbow
Fig. SP645

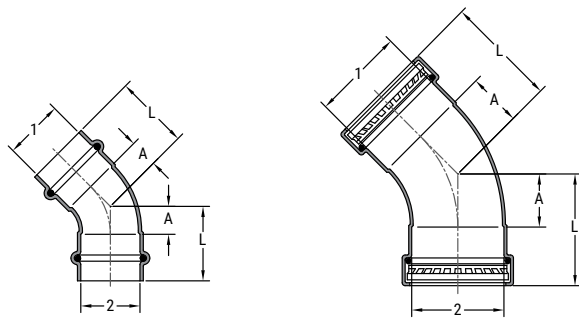

SCI Press – Copper 45° Street Elbow
Fig. SP649

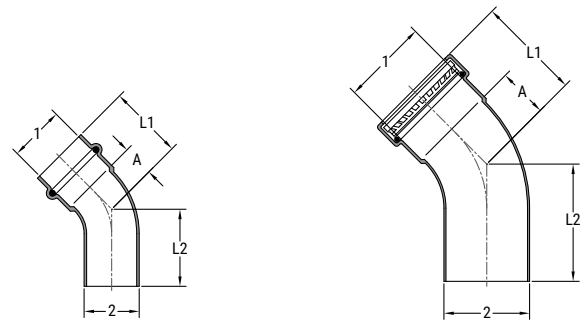

SP645 CU P X P 45 ELL

Inlet 1	Inlet 2	A	L	Weight
in	in	in/mm	in/mm	lbs/kg
½	½	0.354 9.000	1.102 28.000	0.09 0.04
¾	¾	0.512 13.000	1.398 35.500	0.14 0.06
1	1	0.531 13.500	1.417 36.000	0.22 0.10
1¼	1¼	0.886 22.500	1.969 50.000	0.32 0.15
1½	1½	0.906 23.000	2.303 58.500	0.62 0.28
2	2	0.886 22.500	2.441 62.000	0.84 0.38
2½	2½	1.516 38.500	3.189 81.000	1.61 0.73
3	3	1.752 44.500	3.701 94.000	2.34 1.06
4	4	2.283 58.000	4.626 117.500	4.22 1.91

SP649 CU P X MS STREET 45 ELL

Inlet 1	Inlet 2	A	L1	L2	Weight
in	in	in/mm	in/mm	in/mm	lbs/kg
½	½	0.354 9.000	1.102 28.000	1.220 31.000	0.09 0.04
¾	¾	0.512 13.000	1.398 35.500	1.457 37.000	0.15 0.07
1	1	0.630 16.000	1.516 38.500	1.575 40.000	0.20 0.09
1¼	1¼	0.886 22.500	1.969 50.000	1.909 48.500	0.31 0.14
1½	1½	0.906 23.000	2.303 58.500	2.362 60.000	0.59 0.27
2	2	0.886 22.500	2.441 62.000	2.756 70.000	0.82 0.37
2½	2½	1.516 38.500	3.189 81.000	3.583 91.000	1.56 0.71
3	3	1.752 44.500	3.701 94.000	4.094 104.000	2.19 0.99
4	4	2.283 58.000	4.626 117.500	5.079 129.000	4.02 1.82



asc-es.com

Building connections that last™

SCI Press – Copper Tee Fig. SP620

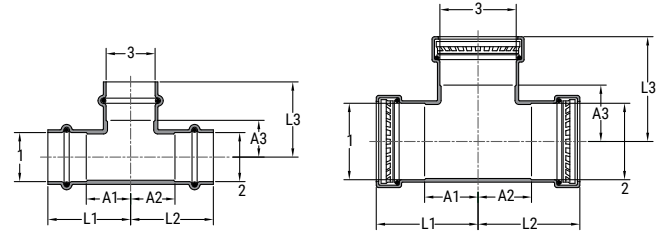
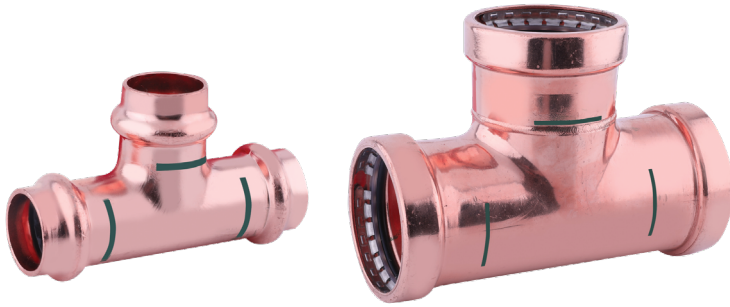

SP690 CU P x P x P Tee

Inlet 1	Inlet 2	Inlet 3	A1	A2	A3	L1	L2	L3	Weight
in	in	in	in/mm	in/mm	in/mm	in/mm	in/mm	in/mm	lbs/kg
½	½	½	0.807 20.500	0.807 20.500	0.531 13.500	1.555 39.500	1.555 39.500	1.280 32.500	0.17 0.07
¾	¾	¾	0.906 23.000	0.906 23.000	0.709 18.000	1.791 45.500	1.791 45.500	1.594 40.500	0.29 0.13
1	1	1	1.024 26.000	1.024 26.000	0.846 21.500	1.909 48.500	1.909 48.500	1.732 44.000	0.40 0.18
1¼	1¼	1¼	1.043 26.500	1.043 26.500	0.886 22.500	2.126 54.000	2.126 54.000	1.969 50.000	0.52 0.23
1½	1½	1½	1.220 31.000	1.220 31.000	1.358 34.500	2.618 66.500	2.618 66.500	2.756 70.000	0.88 0.40
2	2	2	1.437 36.500	1.437 36.500	1.594 40.500	2.992 76.000	2.992 76.000	3.150 80.000	1.10 0.50
2½	2½	2½	1.850 47.000	1.850 47.000	1.949 49.500	3.524 89.500	3.524 89.500	3.622 92.000	2.29 1.04
3	3	3	2.106 53.500	2.106 53.500	2.224 56.500	4.055 103.000	4.055 103.000	4.055 106.000	3.25 1.48
4	4	4	2.618 66.500	2.618 66.500	2.736 69.500	4.961 126.000	4.961 126.000	4.961 129.000	5.84 2.65



asc-es.com

Building connections that last™

SCI Press – Copper Reducing Tee Fig. SP620R

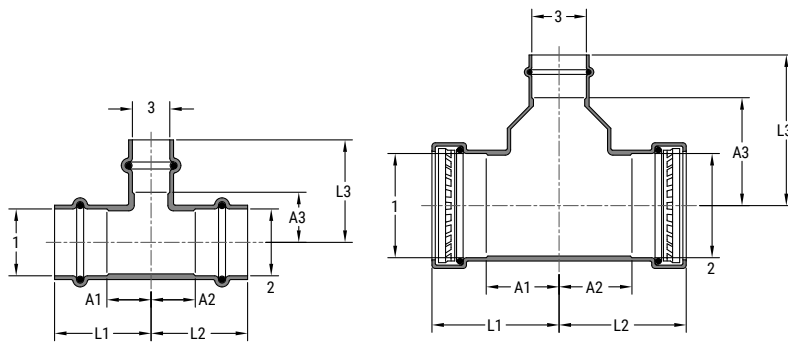
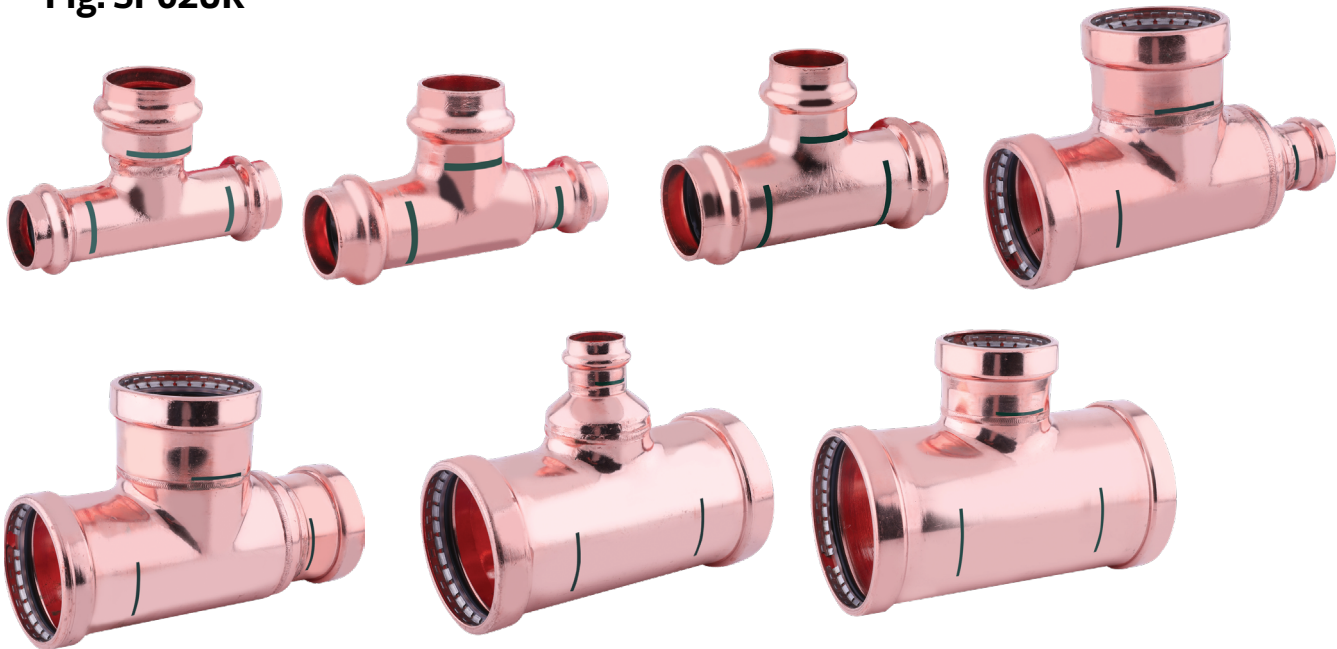

SP620R P x P x P Reducing Tee

Inlet 1	Inlet 2	Inlet 3	A1	A2	A3	L1	L2	L3	Weight
in	in	in	in/mm	in/mm	in/mm	in/mm	in/mm	in/mm	lbs/kg
½	½	¾	0.965 24.500	0.965 24.500	0.650 16.500	1.713 43.500	1.713 43.500	1.535 39.000	0.29 0.13
½	½	1	0.965 24.500	0.965 24.500	0.846 21.500	1.713 43.500	1.713 43.500	1.732 44.000	0.32 0.15
¾	½	½	0.748 19.000	1.004 25.500	0.689 17.500	1.630 41.500	1.752 44.500	1.437 36.500	0.28 0.13
¾	½	¾	0.906 23.000	1.122 28.500	0.709 18.000	1.791 45.500	1.870 47.500	1.594 40.500	0.33 0.15
¾	¾	½	0.748 19.000	0.748 19.000	0.689 17.500	1.634 41.500	1.634 41.500	1.437 36.500	0.29 0.13



asc-es.com

Building connections that last™

SCI Press – Copper Reducing Tee
Fig. SP620R

SP620R P x P x P Reducing Tee

Inlet 1	Inlet 2	Inlet 3	A1	A2	A3	L1	L2	L3	Weight
in	in	in	in/mm	in/mm	in/mm	in/mm	in/mm	in/mm	lbs/kg
¾	¾	1	1.024 26.000	1.024 26.000	1.142 29.000	1.909 48.500	1.909 48.500	2.028 51.500	0.40 0.18
1	½	¾	0.906 23.000	1.378 35.000	0.846 21.500	1.791 45.500	2.126 54.000	1.732 44.000	0.40 0.18
1	½	1	1.024 26.000	1.476 37.500	0.846 21.500	1.909 48.500	2.224 56.500	1.732 44.000	0.46 0.21
1	¾	½	0.748 19.000	1.024 26.000	0.846 21.500	1.634 41.500	1.909 48.500	1.594 40.500	0.37 0.17
1	¾	¾	0.906 23.000	1.122 28.500	0.846 21.500	1.791 45.500	2.008 51.000	1.732 44.000	0.40 0.18
1	1	½	0.748 19.000	1.142 29.000	0.846 21.500	1.634 41.500	2.028 51.500	1.594 40.500	0.38 0.17
1	1	¾	0.906 23.000	0.906 23.000	0.846 21.500	1.791 45.500	1.791 45.500	1.732 44.000	0.41 0.19
1	¾	1	1.024 26.000	1.280 32.500	0.846 21.500	1.909 48.500	2.165 55.000	1.732 44.000	0.45 0.21
1	1	1¼	1.043 26.500	1.043 26.500	1.240 31.500	1.929 49.000	1.929 49.000	2.323 59.000	0.57 0.26
1¼	½	1¼	1.043 26.500	1.870 47.500	1.122 28.500	2.126 54.000	2.618 66.500	2.205 56.000	0.60 0.27
1¼	¾	½	0.689 17.500	1.299 33.000	1.181 30.000	1.772 45.000	2.185 55.500	1.929 49.000	0.47 0.21
1¼	¾	¾	0.787 20.000	1.398 35.500	1.083 27.500	1.870 47.500	2.283 58.000	1.969 50.000	0.53 0.24
1¼	¾	1	0.906 23.000	1.496 38.000	1.161 29.500	1.988 50.500	2.382 60.500	2.047 52.000	0.56 0.25
1¼	¾	1¼	1.043 26.500	1.555 39.500	0.886 22.500	2.126 54.000	2.441 62.000	1.969 50.000	0.61 0.28
1¼	1	½	0.689 17.500	1.201 30.500	1.181 30.000	1.772 45.000	2.087 53.000	1.929 49.000	0.46 0.21
1¼	1	¾	0.787 20.000	1.220 31.000	1.083 27.500	1.870 47.500	2.106 53.500	1.969 50.000	0.46 0.21
1¼	1	1	0.906 23.000	1.339 34.000	1.161 29.500	1.988 50.500	2.224 56.500	2.047 52.000	0.51 0.23
1¼	1	1¼	1.043 26.500	1.358 34.500	0.886 22.500	2.126 54.000	2.244 57.000	1.969 50.000	0.55 0.25
1¼	1¼	½	0.689 17.500	0.689 17.500	1.181 30.000	1.772 45.000	1.772 45.000	1.929 49.000	0.47 0.21
1¼	1¼	¾	0.787 20.000	0.787 20.000	1.083 27.500	1.870 47.500	1.870 47.500	1.969 50.000	0.51 0.23
1¼	1¼	1	0.906 23.000	0.906 23.000	1.161 29.500	1.988 50.500	1.988 50.500	2.047 52.000	0.55 0.25
1½	½	1½	1.220 31.000	2.146 54.500	1.358 34.500	2.618 66.500	2.894 73.500	2.756 70.000	0.70 0.32



asc-es.com

Building connections that last™

SCI Press – Copper Reducing Tee
Fig. SP620R

SP620R P x P x P Reducing Tee

Inlet 1	Inlet 2	Inlet 3	A1	A2	A3	L1	L2	L3	Weight
in	in	in	in/mm	in/mm	in/mm	in/mm	in/mm	in/mm	lbs/kg
1½	1	¾	0.728 18.500	1.476 37.500	1.201 30.500	2.126 54.000	2.362 60.000	2.087 53.000	0.76 0.35
1½	1	1	0.866 22.000	1.496 38.000	1.201 30.500	2.264 57.500	2.382 60.500	2.087 53.000	0.81 0.37
1½	1	1½	1.220 31.000	1.811 46.000	1.358 34.500	2.618 66.500	2.697 68.500	2.756 70.000	1.10 0.50
1½	1¼	¾	0.728 18.500	1.201 30.500	1.201 30.500	2.126 54.000	2.283 58.000	2.087 53.000	0.74 0.34
1½	1¼	1	0.472 12.000	1.260 32.000	1.201 30.500	1.870 47.500	2.343 59.500	2.087 53.000	0.81 0.37
1½	1¼	1¼	0.984 25.000	1.457 37.000	1.161 29.500	2.382 60.500	2.539 64.500	2.244 57.000	0.86 0.39
1½	1½	1½	0.531 13.500	0.531 13.500	1.161 29.500	1.929 49.000	1.929 49.000	1.909 48.500	0.70 0.32
1½	1½	¾	0.728 18.500	0.728 18.500	1.201 30.500	2.126 54.000	2.126 54.000	2.087 53.000	0.81 0.37
1½	1½	1	0.866 22.000	0.866 22.000	1.201 30.500	2.264 57.500	2.264 57.500	2.087 53.000	0.85 0.39
1½	1½	1¼	0.984 25.000	0.984 25.000	1.161 29.500	2.382 60.500	2.382 60.500	2.244 57.000	0.89 0.41
2	½	2	1.437 36.500	2.520 64.000	1.594 40.500	2.992 76.000	3.268 83.000	3.150 80.000	1.17 0.53
2	¾	2	1.437 36.500	2.933 74.500	1.594 40.500	2.992 76.000	3.819 97.000	3.150 80.000	1.17 0.53
2	1	2	1.437 36.500	2.815 71.500	1.594 40.500	2.992 76.000	3.701 94.000	3.150 80.000	1.32 0.60
2	1¼	1¼	1.083 27.500	1.811 46.000	1.811 46.000	2.638 67.000	2.894 73.500	2.894 73.500	1.17 0.53
2	1½	¾	0.866 22.000	1.457 37.000	1.516 38.500	2.421 61.500	2.854 72.500	2.402 61.000	1.02 0.46
2	1½	1	0.984 25.000	1.535 39.000	1.555 39.500	2.539 64.500	2.933 74.500	2.441 62.000	1.10 0.50
2	1½	1¼	1.102 28.000	1.693 43.000	1.516 38.500	2.657 67.500	3.091 78.500	2.598 66.000	1.23 0.56
2	1½	1½	1.220 31.000	1.850 47.000	1.594 40.500	2.776 70.500	3.248 82.500	2.992 76.000	1.36 0.62
2	1½	2	1.437 36.500	2.028 51.500	1.594 40.500	2.992 76.000	3.425 87.000	3.150 80.000	1.32 0.60
2	2	½	0.866 22.000	0.866 22.000	1.772 45.000	2.421 61.500	2.421 61.500	2.520 64.000	0.88 0.40
2	2	¾	0.866 22.000	0.866 22.000	1.516 38.500	2.421 61.500	2.421 61.500	2.402 61.000	0.93 0.42
2	2	1	0.984 25.000	0.984 25.000	1.555 39.500	2.539 64.500	2.539 64.500	2.441 62.000	0.99 0.45



asc-es.com

Building connections that last™

SCI Press – Copper Reducing Tee
Fig. SP620R

SP620R P x P x P Reducing Tee

Inlet 1	Inlet 2	Inlet 3	A1	A2	A3	L1	L2	L3	Weight
in	in	in	in/mm	in/mm	in/mm	in/mm	in/mm	in/mm	lbs/kg
2	2	1¼	1.102 28.000	1.102 28.000	1.516 38.500	2.657 67.500	2.657 67.500	2.598 66.000	1.06 0.48
2	2	1½	1.220 31.000	1.220 31.000	1.594 40.500	2.776 70.500	2.776 70.500	2.992 76.000	1.10 0.50
2½	¾	2½	1.850 47.000	3.465 88.000	1.949 49.500	3.524 89.500	4.350 110.500	3.622 92.000	2.06 0.93
2½	1	2½	1.850 47.000	3.307 84.000	1.949 49.500	3.524 89.500	4.193 106.500	3.622 92.000	2.02 0.91
2½	1¼	2½	1.850 47.000	3.169 80.500	1.949 49.500	3.524 89.500	4.252 108.000	3.622 92.000	2.08 0.94
2½	1½	2½	1.850 47.000	3.051 77.500	1.949 49.500	3.524 89.500	4.449 113.000	3.622 92.000	2.21 1.00
2½	2	¾	1.555 39.500	1.673 42.500	2.992 76.000	3.228 82.000	3.228 82.000	3.878 98.500	1.40 0.63
2½	2	1	1.555 39.500	2.539 64.500	2.874 73.000	3.228 82.000	4.094 104.000	3.760 95.500	1.42 0.65
2½	2	1½	1.555 39.500	2.539 64.500	2.618 66.500	3.228 82.000	4.094 104.000	4.016 102.000	1.67 0.76
2½	2	2	1.555 39.500	2.539 64.500	1.949 49.500	3.228 82.000	4.094 104.000	3.504 89.000	1.84 0.84
2½	2	2½	1.850 47.000	2.795 71.000	1.949 49.500	3.524 89.500	4.350 110.500	3.622 92.000	2.17 0.98
2½	2½	½	1.555 39.500	1.555 39.500	3.150 80.000	3.228 82.000	3.228 82.000	3.898 99.000	1.48 0.67
2½	2½	¾	1.555 39.500	1.555 39.500	2.992 76.000	3.228 82.000	3.228 82.000	3.878 98.500	1.46 0.66
2½	2½	1	1.555 39.500	1.555 39.500	2.874 73.000	3.228 82.000	3.228 82.000	3.760 95.500	1.52 0.69
2½	2½	1¼	1.555 39.500	1.555 39.500	2.736 69.500	3.228 82.000	3.228 82.000	3.819 97.000	1.63 0.74
2½	2½	1½	1.555 39.500	1.555 39.500	2.618 66.500	3.228 82.000	3.228 82.000	4.016 102.000	1.81 0.82
2½	2½	2	1.555 39.500	1.555 39.500	1.949 49.500	3.228 82.000	3.228 82.000	3.504 89.000	1.94 0.88
3	¾	3	2.106 53.500	3.957 100.500	2.224 56.500	4.055 103.000	4.843 123.000	4.173 106.000	2.96 1.34
3	1	3	2.106 53.500	3.819 97.000	2.224 56.500	4.055 103.000	4.705 119.500	4.173 106.000	2.89 1.31
3	1¼	3	2.106 53.500	3.681 93.500	2.224 56.500	4.055 103.000	4.764 121.000	4.173 106.000	2.93 1.33
3	1½	3	2.106 53.500	3.563 90.500	2.224 56.500	4.055 103.000	4.961 126.000	4.173 106.000	3.05 1.38
3	2	2	1.555 39.500	2.795 71.000	2.244 57.000	3.504 89.000	4.350 110.500	3.799 96.500	2.33 1.06



asc-es.com

Building connections that last™

SCI Press – Copper Reducing Tee
Fig. SP620R

SP620R P x P x P Reducing Tee

Inlet 1	Inlet 2	Inlet 3	A1	A2	A3	L1	L2	L3	Weight
in	in	in	in/mm	in/mm	in/mm	in/mm	in/mm	in/mm	lbs/kg
3	2	2½	1.870 47.500	3.051 77.500	2.185 55.500	3.819 97.000	4.606 117.000	3.858 98.000	2.61 1.18
3	2	3	2.106 53.500	3.307 84.000	2.224 56.500	4.055 103.000	4.862 123.500	4.173 106.000	2.96 1.34
3	2½	2	1.555 39.500	2.539 64.500	2.244 57.000	3.504 89.000	4.213 107.000	3.799 96.500	2.47 1.12
3	2½	2½	1.870 47.500	2.795 71.000	2.185 55.500	3.819 97.000	4.469 113.500	3.858 98.000	2.87 1.30
3	2½	3	2.106 53.500	3.051 77.500	2.224 56.500	4.055 103.000	4.724 120.000	4.173 106.000	3.18 1.44
3	3	½	1.555 39.500	1.555 39.500	3.445 87.500	3.504 89.000	3.504 89.000	4.193 106.500	1.95 0.88
3	3	¾	1.555 39.500	1.555 39.500	3.287 83.500	3.504 89.000	3.504 89.000	4.173 106.000	1.99 0.90
3	3	1	1.555 39.500	1.555 39.500	3.169 80.500	3.504 89.000	3.504 89.000	4.055 103.000	2.06 0.94
3	3	1¼	1.555 39.500	1.555 39.500	3.031 77.000	3.504 89.000	3.504 89.000	4.114 104.500	2.13 0.97
3	3	1½	1.555 39.500	1.555 39.500	2.913 74.000	3.504 89.000	3.504 89.000	4.311 109.500	2.33 1.06
3	3	2	1.555 39.500	1.555 39.500	2.244 57.000	3.504 89.000	3.504 89.000	3.799 96.500	2.50 1.13
3	3	2½	1.870 47.500	1.870 47.500	2.185 55.500	3.819 97.000	3.819 97.000	3.858 98.000	2.90 1.32
4	3	2	1.634 41.500	2.795 71.000	2.677 68.000	3.976 101.000	4.744 120.500	4.232 107.500	4.04 1.83
4	3	3	2.126 54.000	3.327 84.500	2.697 68.500	4.469 113.500	5.276 134.000	4.646 118.000	4.92 2.23
4	4	½	1.634 41.500	1.634 41.500	3.878 98.500	3.976 101.000	3.976 101.000	4.626 117.500	3.37 1.53
4	4	¾	1.634 41.500	1.634 41.500	3.720 94.500	3.976 101.000	3.976 101.000	4.606 117.000	3.40 1.54
4	4	1	1.634 41.500	1.634 41.500	3.602 91.500	3.976 101.000	3.976 101.000	4.488 114.000	3.65 1.66
4	4	1¼	1.634 41.500	1.634 41.500	3.465 88.000	3.976 101.000	3.976 101.000	4.547 115.500	3.67 1.66
4	4	1½	1.634 41.500	1.634 41.500	3.346 85.000	3.976 101.000	3.976 101.000	4.744 120.500	3.79 1.72
4	4	2	1.634 41.500	1.634 41.500	2.677 68.000	3.976 101.000	3.976 101.000	4.232 107.500	4.02 1.82
4	4	2½	1.909 48.500	1.909 48.500	2.677 68.000	4.252 108.000	4.252 108.000	4.350 110.500	4.54 2.06
4	4	3	2.126 54.000	2.126 54.000	2.697 68.500	4.469 113.500	4.469 113.500	4.646 118.000	4.86 2.20



asc-es.com

Building connections that last™

SCI Press – Copper FPT Female Adapter Tee
Fig. SP628

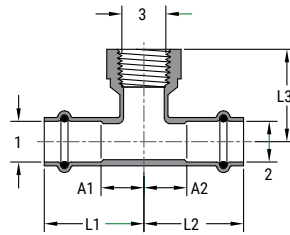
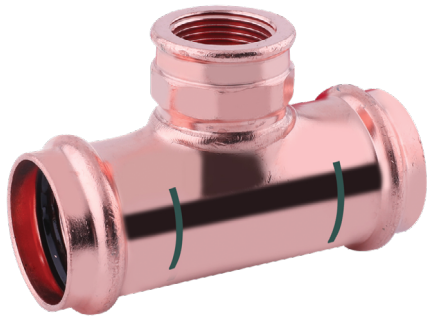

SP628 CU X P X P X FT ADPT TEE

Inlet 1	Inlet 2	Inlet 3	A1	A2	L1	L2	L3	Weight
in	in	in	in/mm	in/mm	in/mm	in/mm	in/mm	lbs/kg
½	½	½	0.807 20.500	0.807 20.500	1.555 39.500	1.555 39.500	1.437 36.500	0.25 0.11
¾	¾	¾	0.906 23.000	0.906 23.000	1.791 45.500	1.791 45.500	1.634 41.500	0.35 0.16

SCI Press – Copper FPT Female Reducing Adapter Tee
Fig. SP628R

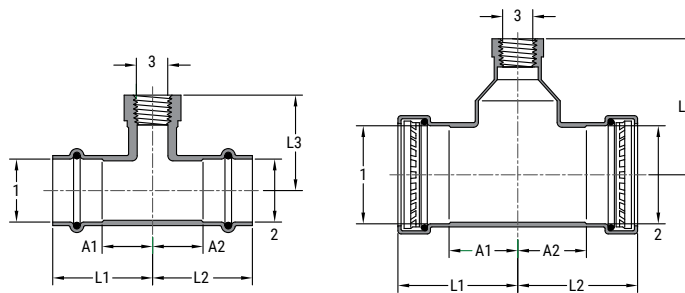

SP628R P X P X FT RED TEE

Inlet 1	Inlet 2	Inlet 3	A1	A2	L1	L2	L3	Weight
in	in	in	in/mm	in/mm	in/mm	in/mm	in/mm	lbs/kg
¾	¾	¼	0.748 19.000	0.748 19.000	4.469 41.500	1.634 41.500	1.339 34.000	0.25 0.12
¾	¾	½	0.906 23.000	0.906 23.000	1.791 45.500	1.791 45.500	1.398 35.500	0.30 0.14
1	1	½	0.906 23.000	0.906 23.000	1.791 45.500	1.791 45.500	1.713 43.500	0.42 0.19



asc-es.com

Building connections that last™

SCI Press – Copper FPT Female Reducing Adapter Tee
Fig. SP628R

SP628R P X P X FT RED TEE

Inlet 1	Inlet 2	Inlet 3	A1	A2	L1	L2	L3	Weight
in	in	in	in/mm	in/mm	in/mm	in/mm	in/mm	lbs/kg
1	1	¾	1.024 26.000	1.024 26.000	1.909 48.500	1.909 48.500	1.850 47.000	0.49 0.22
1¼	1¼	½	0.787 20.000	0.787 20.000	1.870 47.500	1.870 47.500	1.673 42.500	0.53 0.24
1¼	1¼	¾	0.906 23.000	0.906 23.000	1.988 50.500	1.988 50.500	1.811 46.000	0.60 0.27
1½	1½	½	0.728 18.500	0.728 18.500	2.126 54.000	2.126 54.000	1.831 46.500	0.81 0.37
1½	1½	¾	0.866 22.000	0.866 22.000	2.264 57.500	2.264 57.500	1.969 50.000	0.90 0.41
2	2	½	0.984 25.000	0.984 25.000	2.539 64.500	2.539 64.500	2.087 53.000	1.15 0.52
2	2	¾	0.984 25.000	0.984 25.000	2.539 64.500	2.539 64.500	2.303 58.500	1.30 0.59
2½	2½	¾	1.555 39.500	1.555 39.500	3.228 82.000	3.228 82.000	3.622 92.000	1.54 0.70
2½	2½	2	1.555 39.500	1.555 39.500	3.228 82.000	3.228 82.000	3.287 83.500	2.15 0.98
3	3	¾	1.555 39.500	1.555 39.500	3.504 89.000	3.504 89.000	3.917 99.500	2.04 0.93
3	3	2	1.555 39.500	1.555 39.500	3.504 89.000	3.504 89.000	3.583 91.000	2.78 1.26
4	4	¾	1.634 41.500	1.634 41.500	3.976 101.000	3.976 101.000	4.350 110.500	3.48 1.58
4	4	2	1.634 41.500	1.634 41.500	3.976 101.000	3.976 101.000	4.016 102.000	4.30 1.95



asc-es.com

Building connections that last™

SCI Press – Copper MPT Male Adapter Fig. SP607

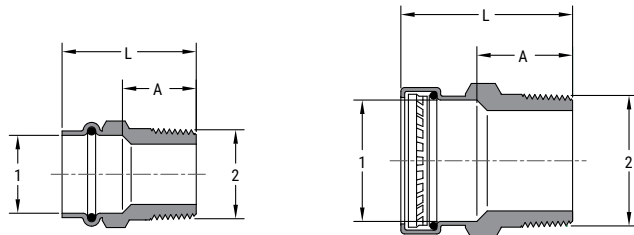

SCI® Press – Copper MPT Male Reducing Adapter Fig. SP607R

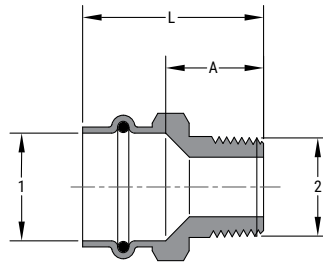
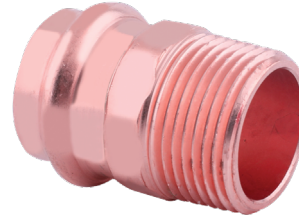

SP607 P X MT ADPT CPLG

Inlet 1	Inlet 2	A	L	Weight
in	in	in/mm	in/mm	lbs/kg
½	½	0.945 24.000	1.693 43.000	0.11 0.05
¾	¾	1.004 25.500	1.890 48.000	0.19 0.09
1	1	1.083 27.500	1.969 50.000	0.28 0.13
1¼	1¼	1.122 28.500	2.205 56.000	0.37 0.17
1½	1½	1.240 31.500	2.638 67.000	0.63 0.29
2	2	1.240 31.500	2.795 71.000	0.89 0.40
2½	2½	2.106 53.500	3.780 96.000	1.62 0.73
3	3	2.185 55.500	4.134 105.000	2.23 1.01
4	4	2.343 59.500	4.685 119.000	3.82 1.73

SP607R P X MT RED ADPT CPLG

Inlet 1	Inlet 2	A	L	Weight
in	in	in/mm	in/mm	lbs/kg
½	¾	0.906 23.000	1.654 42.000	0.08 0.04
½	¾	0.984 25.000	1.732 44.000	0.19 0.09
¾	½	1.004 25.500	1.890 48.000	0.17 0.08
¾	1	1.161 29.500	2.047 52.000	0.30 0.14
1	¾	1.043 26.500	1.929 49.000	0.24 0.11
1	1¼	1.201 30.500	2.087 53.000	0.45 0.20
1¼	1	1.122 28.500	2.205 56.000	0.34 0.15
1¼	1½	1.201 30.500	2.283 58.000	0.59 0.27
1½	1¼	1.161 29.500	2.559 65.000	0.59 0.27
1½	2	1.240 31.500	2.638 67.000	1.00 0.45
2	1½	1.280 32.500	2.835 72.000	0.92 0.42



asc-es.com

Building connections that last™

SCI Press – Copper MPT Male Street Adapter Fig. SP602

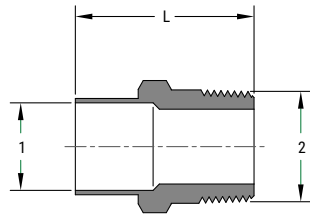
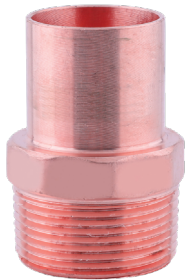

SCI Press – Copper MPT Male Street Reducer Fig. SP602R

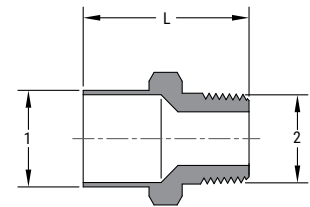

SP602 MS X MT ADPT CPLG

Inlet 1	Inlet 2	L	Weight
in	in	in/mm	lbs/kg
½	½	1.772 45.000	0.11 0.05
¾	¾	1.969 50.000	0.16 0.07
1	1	2.126 54.000	0.24 0.11
1¼	1¼	2.480 63.000	0.51 0.23
1½	1½	2.874 73.000	0.59 0.27
2	2	3.189 81.000	0.91 0.41

SP602R MS X MT RED ADPT CPLG

Inlet 1	Inlet 2	L	Weight
in	in	in/mm	lbs/kg
½	¾	1.693 43.000	0.07 0.03
½	¾	1.929 49.000	0.16 0.07
¾	½	1.929 49.000	0.10 0.05
1	¾	1.969 50.000	0.18 0.08



asc-es.com

Building connections that last™

SCI Press – Copper FPT Female Adapter
Fig. SP608

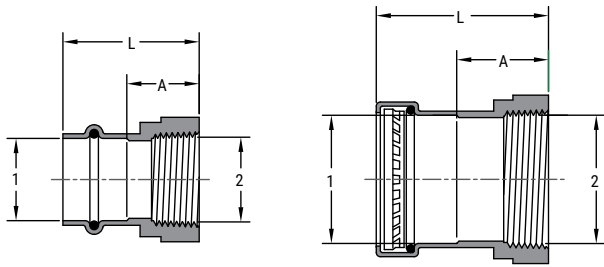
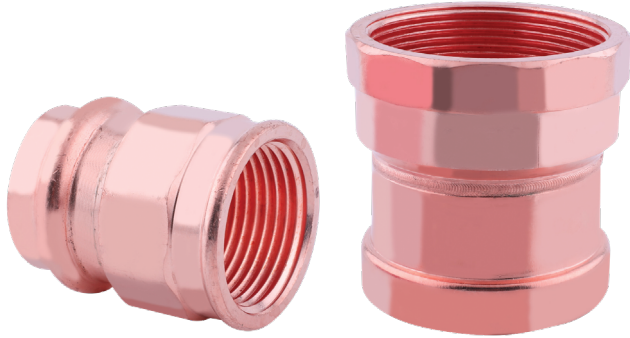

SP608 CU P X FT ADPT CPLG

Inlet 1	Inlet 2	A	L	Weight
in	in	in/mm	in/mm	lbs/kg
½	½	0.866 22.000	1.614 41.000	0.10 0.05
¾	¾	0.925 23.500	1.811 46.000	0.17 0.08
1	1	1.004 25.500	1.890 48.000	0.25 0.11
1¼	1¼	1.122 28.500	2.205 56.000	0.34 0.15
1½	1½	1.122 28.500	2.520 64.000	0.53 0.24
2	2	1.280 32.500	2.835 72.000	0.78 0.35
2½	2½	1.909 48.500	3.583 91.000	1.60 0.73
3	3	1.988 50.500	3.937 100.000	2.20 1.00
4	4	2.028 51.500	4.370 111.000	3.80 1.72

SCI Press – Copper FPT Female Reducing Adapter
Fig. SP608R

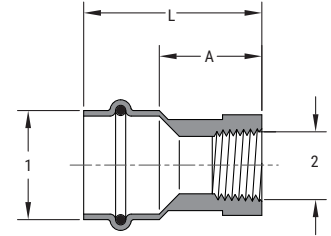
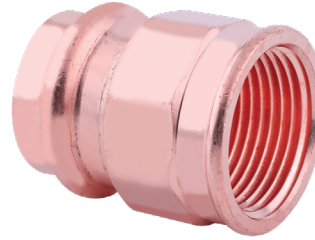

SP608R CU P X FT RED ADPT CPLG

Inlet 1	Inlet 2	A	L	Weight
in	in	in/mm	in/mm	lbs/kg
½	¾	0.669 17.000	1.417 36.000	0.09 0.04
½	¾	0.906 23.000	1.654 42.000	0.15 0.07
¾	½	0.728 18.500	1.614 41.000	0.17 0.08
1	½	1.201 30.500	2.087 53.000	0.29 0.13
1	¾	0.846 21.500	1.732 44.000	0.22 0.10
1	1¼	1.240 31.500	2.126 54.000	0.46 0.21
1¼	1	1.004 25.500	2.087 53.000	0.29 0.13
1¼	1½	1.122 28.500	2.205 56.000	0.62 0.28
1½	1¼	1.083 27.500	2.480 63.000	0.46 0.21



asc-es.com

Building connections that last™

SCI Press – Copper Flange Adapter Fig. SP616

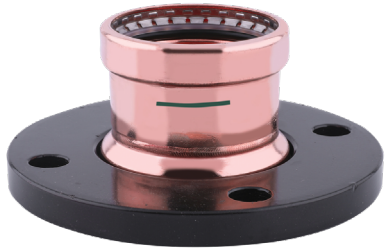

Allows for a direct connection of Class 125 or Class 150 flange.

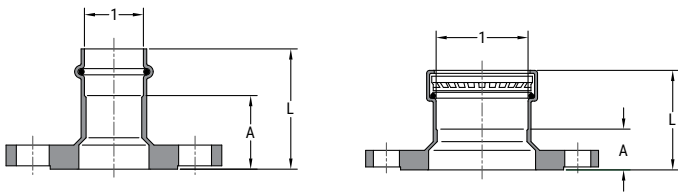

SP616 CU FLNG ADPTR, 4-BOLT

Inlet 1	A	L	Weight
in	in	in/mm	lbs/kg
1	1.398 35.500	2.283 58.000	2.80 1.27
1¼	1.201 30.500	2.283 58.000	3.20 1.45
1½	1.201 30.500	2.598 66.000	3.86 1.75
2	1.201 30.500	2.756 70.000	5.49 2.49
2½	1.161 29.500	2.835 72.000	6.27 2.84
3	1.398 35.500	3.346 85.000	7.63 3.46
4	1.398 35.500	3.740 95.000	11.87 5.39

SCI Press – Copper End Cap Fig. SP600

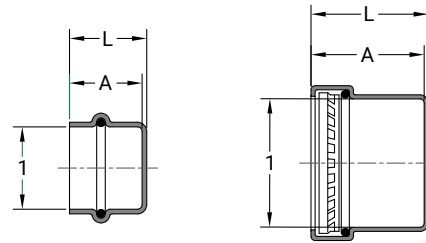
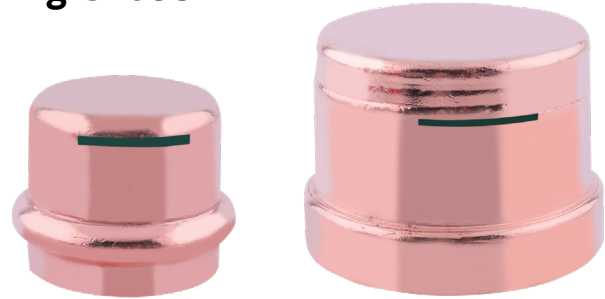

SP600 CU END CAP

Inlet 1	D	L	Weight
in	in	in/mm	lbs/kg
½	0.748 19.00	0.945 24.000	0.06 0.03
¾	0.886 22.500	1.063 27.000	0.09 0.04
1	0.886 22.500	1.063 27.000	0.12 0.05
1¼	1.083 27.500	1.260 32.000	0.19 0.08
1½	1.398 35.500	1.693 43.000	0.33 0.15
2	1.555 39.500	1.850 47.000	0.44 0.20
2½	1.673 42.500	2.421 61.500	0.74 0.34
3	1.949 49.500	2.697 68.500	1.03 0.46
4	2.343 59.500	3.051 77.500	1.85 0.84



asc-es.com

Building connections that last™

SCI Press – Copper Union
Fig. SP655

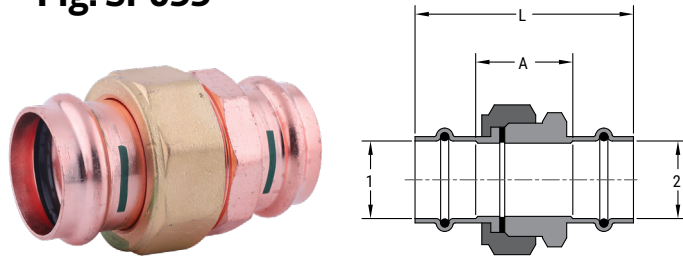

SP655 CU P X P EPDM UNION

Inlet 1	Inlet 2	A	L	Weight
in	in	in/mm	in/mm	lbs/kg
½	½	1.299 33.000	2.795 71.000	0.33 0.15
¾	¾	1.220 31.000	2.992 76.000	0.49 0.22
1	1	1.240 31.500	3.012 76.500	0.86 0.39
1¼	1¼	1.260 32.00.000	3.425 87.000	1.07 0.49
1½	1½	1.299 33.000	4.094 104.000	1.76 0.80
2	2	1.457 37.00	4.567 116.000	2.89 1.31

SCI Press – Copper FPT Female Union
Fig. SP658

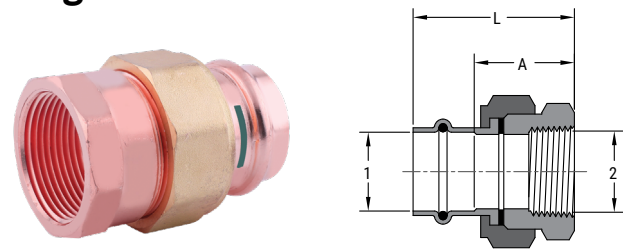

SP658 CU P X FT EPDM UNION

Inlet 1	Inlet 2	A	L	Weight
in	in	in/mm	in/mm	lbs/kg
½	½	1.240 31.500	1.988 50.500	0.29 0.13
¾	¾	1.260 32.000	2.146 54.500	0.41 0.19
1	1	1.378 35.000	2.264 57.500	0.80 0.36
1¼	1¼	1.850 47.000	2.933 74.500	0.97 0.44
1½	1½	1.561 3.500	2.913 74.000	1.68 0.76
2	2	1.752 44.500	3.307 84.000	2.85 1.29

SCI Press – Copper MPT Male Union
Fig. SP657

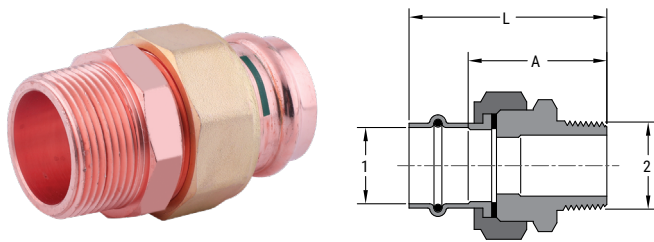

SP657 CU P X MT EPDM ADPT UNION

Inlet 1	Inlet 2	A	L	Weight
in	in	in/mm	in/mm	lbs/kg
½	½	1.831 46.500	2.579 65.500	0.31 0.14
¾	¾	1.831 46.500	2.717 69.000	0.50 0.22
1	1	2.008 51.000	2.894 73.500	0.89 0.40
1¼	1¼	2.185 55.500	3.268 83.000	1.13 0.51
1½	1½	2.224 56.500	3.622 92.000	1.60 0.73
2	2	2.421 61.500	3.976 101.000	2.84 1.29



asc-es.com

Building connections that last™

SCI Press – Copper Coupling No Stop Fig. SP605

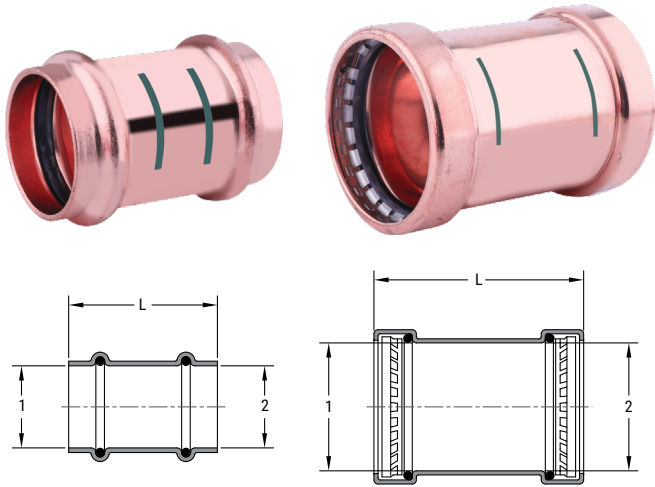

SP605 CU P X P NO STOP CPLG

Inlet 1	Inlet 2	L	Weight
in	in	in/mm	lbs/kg
½	½	1.693 43.000	0.08 0.04
¾	¾	2.047 52.000	0.13 0.06
1	1	2.047 52.000	0.16 0.07
1¼	1¼	2.441 62.000	0.24 0.11
1½	1½	3.031 77.000	0.47 0.22
2	2	3.346 85.000	0.60 0.27
2½	2½	4.331 110.000	1.21 0.55
3	3	4.921 125.000	1.67 0.76
4	4	5.787 147.000	2.88 1.31

SCI Press – Copper Extended Coupling No Stop Fig. SP605L

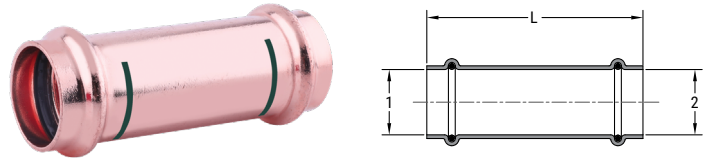

SP605L CU P X P NO STOP EXTND CPLG

Inlet 1	Inlet 2	L	Weight
in	in	in/mm	lbs/kg
¾	¾	3.543 90.000	0.13 0.06
1	1	3.740 95.000	0.16 0.13
1¼	1¼	4.134 105.000	0.24 0.18
1½	1½	4.724 120.000	0.47 0.41
2	2	5.315 135.000	0.60 0.41



asc-es.com

Building connections that last™

SCI Press – Copper Coupling with Stop Fig. SP604



SP604 CU PX P COUPLING

Inlet 1	Inlet 2	A	L	Weight
in	in	in/mm	in/mm	lbs/kg
½	½	0.118 3.000	1.614 41.000	0.08 0.04
¾	¾	0.276 7.000	2.047 52.000	0.13 0.06
1	1	0.276 7.000	2.047 52.000	0.16 0.07
1¼	1¼	0.276 7.000	2.441 62.000	0.24 0.11
1½	1½	0.236 6.000	3.031 77.000	0.47 0.22
2	2	0.236 6.000	3.346 85.000	0.60 0.27
2½	2½	0.984 25.000	4.331 110.000	1.21 0.55
3	3	1.024 26.00	4.921 125.000	1.67 0.76
4	4	1.102 28.000	5.787 147.000	2.88 1.31



asc-es.com

Building connections that last™

SCI Press – Copper Reducing Coupling
Fig. SP604R

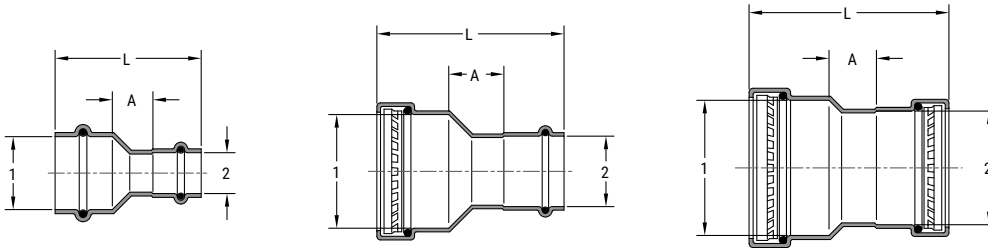
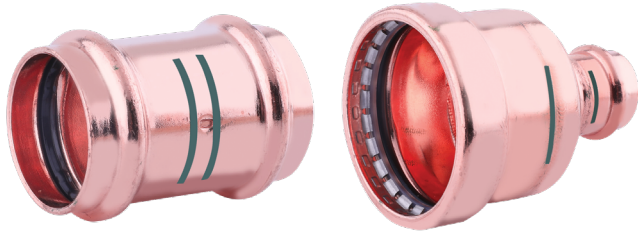

SP604R CU P X P RED COUPLING

Inlet 1	Inlet 2	A	L	Weight
in	in	in/mm	in/mm	lbs/kg
¾	½	0.472 12.000	2.106 53.500	0.12 0.06
1	½	0.630 16.000	2.264 57.500	0.17 0.08
1	¾	0.472 12.000	2.244 57.000	0.18 0.08
1¼	½	0.846 21.500	2.677 68.000	0.26 0.12
1¼	¾	0.689 17.500	2.657 67.500	0.26 0.12
1¼	1	0.531 13.500	2.500 63.500	0.26 0.12
1½	½	1.122 28.500	3.268 83.000	0.43 0.19
1½	¾	0.945 24.000	3.228 82.000	0.43 0.19
1½	1	0.748 19.000	3.031 77.000	0.43 0.19
1½	1¼	0.591 15.000	3.071 78.000	0.40 0.18
2	½	1.555 39.500	3.858 98.000	0.60 0.27
2	¾	1.319 33.500	3.760 95.500	0.60 0.27
2	1	1.102 28.000	3.543 90.000	0.59 0.27
2	1¼	0.945 24.000	3.583 91.000	0.55 0.25

SP604R CU P X P RED COUPLING

Inlet 1	Inlet 2	A	L	Weight
in	in	in/mm	in/mm	lbs/kg
2	1½	0.807 20.500	3.760 95.500	0.60 0.27
2½	1	1.535 39.000	4.094 104.000	0.83 0.38
2½	1¼	1.398 35.500	4.154 105.500	0.85 0.39
2½	1½	1.280 32.500	4.350 110.500	0.99 0.45
2½	2	1.024 26.000	4.252 108.000	1.05 0.47
3	1½	1.535 39.000	4.882 124.000	1.25 0.57
3	2	1.280 32.500	4.783 121.500	1.29 0.59
3	2½	1.024 26.000	4.646 118.000	1.51 0.68
4	2	1.752 44.500	5.650 143.500	2.09 0.95
4	2½	1.496 38.000	5.512 140.000	2.33 1.06
4	3	1.240 31.500	5.531 140.500	2.48 1.13



asc-es.com

Building connections that last™

SCI Press – Copper FTG x Press Reducing Adapter Coupling
Fig. SP609R

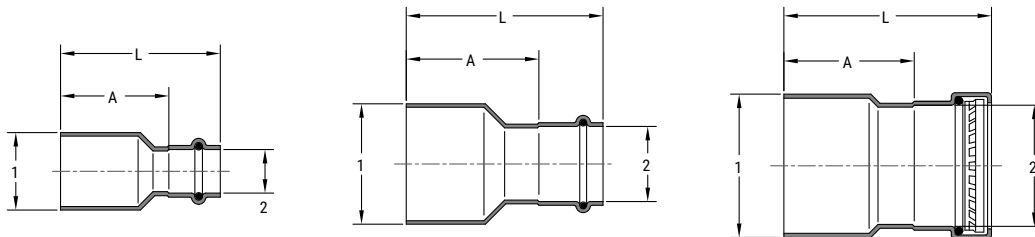
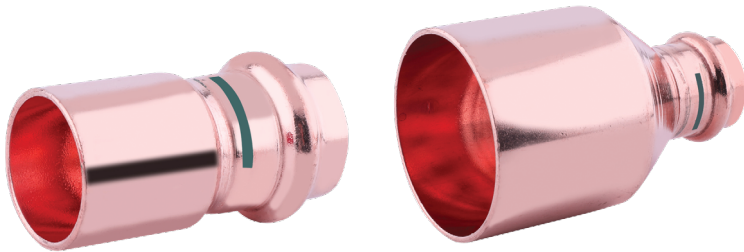

SP609R CU MS X P RED ADPT CPLG

Inlet 1	Inlet 2	A	L	Weight
in	in	in/mm	in/mm	lbs/kg
3/4	1/2	1.398 35.500	2.146 54.500	0.10 0.04
1	1/2	1.575 40.000	2.323 59.000	0.13 0.06
1	3/4	1.358 34.500	2.244 57.000	0.14 0.07
1 1/4	1/2	1.890 48.000	2.638 67.000	0.17 0.08
1 1/4	3/4	1.752 44.500	2.638 67.000	0.20 0.09
1 1/4	1	1.634 41.500	2.520 64.000	0.19 0.09
1 1/2	1/2	2.283 58.000	3.031 77.000	0.32 0.14
1 1/2	3/4	2.224 56.500	3.110 79.000	0.28 0.13
1 1/2	1	2.067 52.500	2.953 75.000	0.30 0.14
1 1/2	1 1/4	1.949 49.500	3.031 77.000	0.30 0.14
2	1/2	2.913 74.000	3.661 93.000	0.54 0.24
2	3/4	2.854 72.500	3.740 95.000	0.53 0.24
2	1	2.657 67.500	3.543 90.000	0.41 0.18

SP609R CU MS X P RED ADPT CPLG

Inlet 1	Inlet 2	A	L	Weight
in	in	in/mm	in/mm	lbs/kg
2	1 1/4	2.500 63.500	3.583 91.000	0.42 0.19
2	1 1/2	2.303 58.500	3.701 94.000	0.46 0.21
2 1/2	1	3.366 85.500	4.252 108.000	0.75 0.34
2 1/2	1 1/4	2.972 75.500	4.055 103.000	0.74 0.34
2 1/2	1 1/2	2.894 73.500	4.291 109.000	0.88 0.40
2 1/2	2	2.697 68.500	4.252 108.000	0.78 0.35
3	1 1/4	3.445 87.500	4.528 115.000	1.01 0.46
3	1 1/2	3.524 89.500	4.921 125.000	1.16 0.53
3	2	3.248 82.500	4.803 122.000	0.89 0.40
3	2 1/2	2.854 72.500	4.528 115.000	1.19 0.54
4	2	4.626 117.500	6.181 157.000	1.89 0.86
4	2 1/2	4.114 104.500	5.787 147.000	2.12 0.96
4	3	3.760 95.500	5.709 145.000	2.30 1.04



asc-es.com

Building connections that last™

SCI Press – Copper Cross-over
Fig. SP624

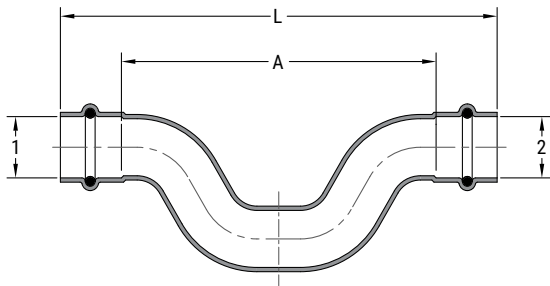
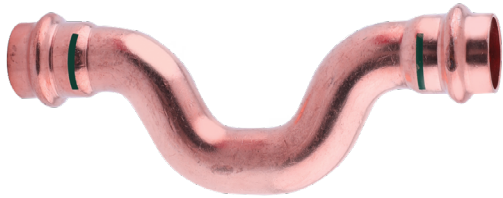

SP624 CU P X P CROSS

Inlet 1	Inlet 1	A	L	Weight
in	in	in/mm	in/mm	lbs/kg
1/2	1/2	3.701 94.000	5.197 132.000	0.24 0.11
3/4	3/4	4.567 116.000	6.339 161.000	0.41 0.19



asc-es.com

Building connections that last™

SCI Press – Copper FTG x FPT Female Street Adapter
Fig. SP603

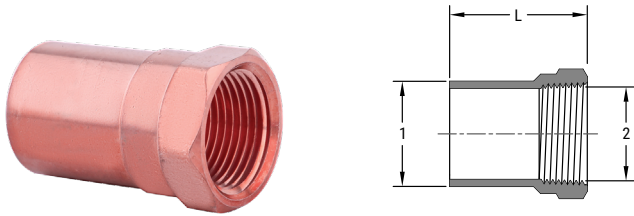

SP603 MS x FT ADPT CPLG

Inlet 1	Inlet 2	L	Weight
in	in	in/mm	lbs/kg
½	½	1.732 44.000	0.11 0.05
¾	¾	1.929 49.000	0.15 0.07
1	1	1.988 50.500	0.27 0.12
1¼	1¼	2.323 59.000	0.40 0.18
1½	1½	2.579 65.500	0.53 0.24
2	2	3.071 78.000	0.85 0.38

SCI Press – Copper FTG x FPT Female Reducing Street Adapter
Fig. SP603R

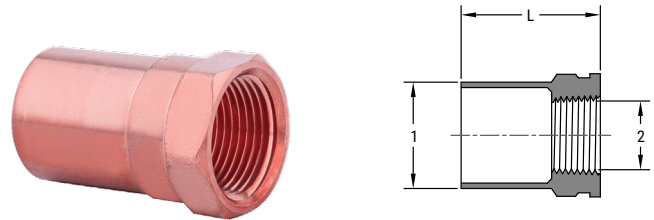

SP603R MS x FT ADPT CPLG

Inlet 1	Inlet 2	L	Weight
in	in	in/mm	lbs/kg
½	¾	1.575 40.000	0.07 0.03
½	¾	1.929 49.000	0.14 0.06
¾	½	1.732 44.000	0.11 0.05
1	½	1.850 47.000	0.18 0.08
1	¾	1.929 49.000	0.22 0.10
1¼	½	2.067 52.500	0.28 0.13

SCI Press – Copper 90° Drop Ear Elbow
Fig. SP698DE

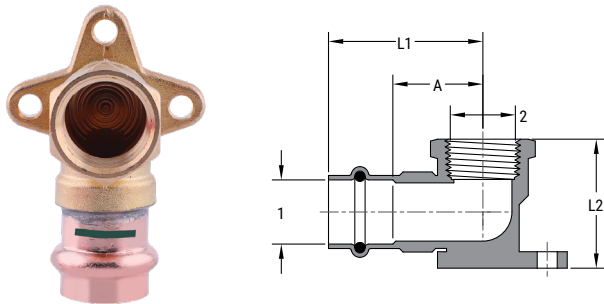

SP698DE P X FPT DROP EAR 90

Inlet 1	Inlet 2	A	L1	L2	Weight
in	in	in/mm	in/mm	in/mm	lbs/kg
½	¾	1.024 26.000	1.772 45.000	1.496 38.000	0.24 0.11
½	½	1.024 26.000	1.772 45.000	1.496 38.000	0.29 0.13
¾	¾	1.240 31.500	2.126 54.000	1.772 45.000	0.43 0.20

SC® Press – Copper 90° Drop Hi Ear Elbow
Fig. SP698HE

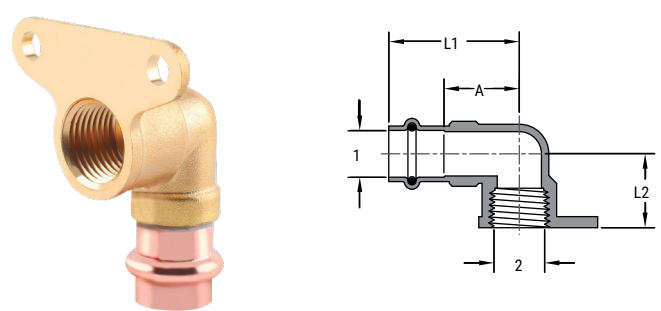

SP698HE P X FPT HI EAR 90

Inlet 1	Inlet 2	A	L1	Weight
in	in	in/mm	in/mm	lbs/kg
½	½	1.024 26.000	1.772 45.000	0.22 0.10



asc-es.com

Building connections that last™

SCI Press – Copper Systems ½" to 2"

For Types K, L, M Hard Copper Tubing (Soft Copper Tubing ½" to 1¼")



Read and understand all instructions before use.

WARNING

Ensure system is drained and depressurized before installation or service.

Use appropriate personal protective equipment.



Failure to follow these instructions could result in serious personal injury and/or property damage.

- 1 Cut copper tubing at right angles to desired length using a rotational type cutter or fine-toothed steel saw.
- 2 Remove all burrs from inside and outside of tubing to prevent cutting sealing element. The surface of the copper must be free of any form of damage to ensure a proper seal.
- 3 Check seal for correct fit. Do not apply additional oils or lubricants. Use only SCI Press EPDM sealing element.
- 4 Mark proper insertion depth as indicated by the SCI Press Insertion Depth Chart. Improper insertion depth may result in an improper seal.

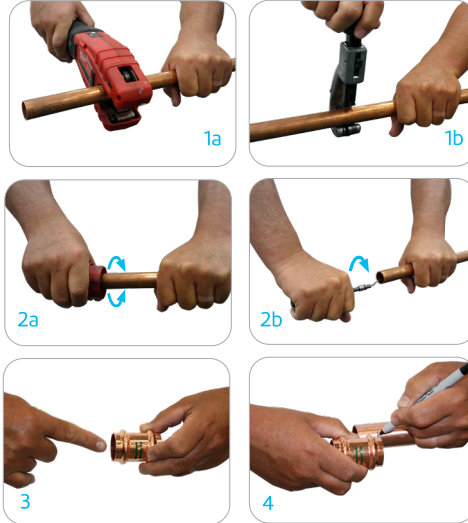

SCI Press Insertion Depth

Size	½	¾	1	1¼	1½	2
Depth	¾	7/8	7/8	1 1/16	1 3/8	1 1/16



- 5 While turning slightly, slide press fitting onto tubing until the tube end contacts the stop in the fitting. A properly inserted fitting lines up with the insertion depth line.



- 6 Install appropriate jaw into the pressing tool. Refer to specific tool manufacturer's instructions.



- 7 Open the jaw and place at right angles on the fitting. Visually check insertion depth using mark on tubing. Both groove halves of the jaw must be engaged with the fitting.

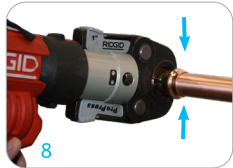

- 8 Start pressing process and hold the trigger until the jaw has completed its cycle. Refer to specific tool manufacturer's instructions.

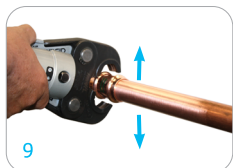

- 9 After pressing, remove the jaw and inspect that the fitting is secured. After visual confirmation of each connection, a system pressure test may be performed in accordance with local code requirements.



asc-es.com

Building connections that last™

SCI Press – Copper Systems 2 ½" to 4" For Types K, L, M Hard Copper Tubing



Read and understand all instructions before use.

WARNING

Ensure system is drained and depressurized before installation or service.

Use appropriate personal protective equipment.



Failure to follow these instructions could result in serious personal injury and/or property damage.

- 1 Cut copper tubing at right angles to desired length using a rotational type cutter or fine-toothed steel saw.
- 2 Remove all burrs from inside and outside of tubing to prevent cutting sealing element. The surface of the copper must be free of any form of damage to ensure a proper seal.
- 3 Check seal for correct fit. Do not apply additional oils or lubricants. Use only SCI Press EPDM sealing element.
- 4 Mark proper insertion depth as indicated by the SCI Press Insertion Depth Chart. Improper insertion depth may result in an improper seal.

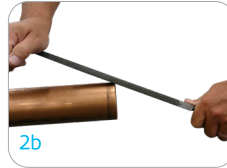
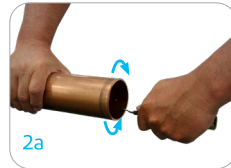

SCI Press Insertion Depth

Size	2½	3	4
Depth	1 11/16	1 15/16	2 5/16



- 5 While turning slightly, slide press fitting onto tubing until the tube end contacts the stop in the fitting. A properly inserted fitting lines up with the insertion depth line.



- 6 SCI Press fitting connections (2½" - 4") must be performed with XL rings only. Use of incorrect rings and/or actuator will result in an improper connection. Refer to specific tool manufacturer's instructions.



- 7 Open the jaw and place at right angles on the fitting. Visually check insertion depth using mark on tubing. Both groove halves of the jaw must be engaged with the fitting.

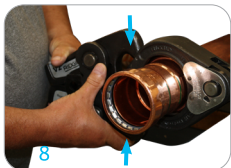

- 8 With actuator inserted into the tool, open the actuator as shown and connect actuator to the ring.



- 9 Place actuator onto ring and start pressing process. Hold the trigger until the actuator has engaged the ring. Refer to specific tool manufacturer's instructions. After visual confirmation of each connection, a system pressure test may be performed in accordance with local code requirements.



asc-es.com

Building connections that last™